

Queensland Code of Practice: Vehicle Modifications (QCOP)

Code S4 Gross Vehicle Mass Rating – Rigid Omnibus

July 2021

© The State of Queensland (Department of Transport and Main Roads) 2021
Queensland Government



<http://creativecommons.org/licenses/by-nd/4.0/>

You are free to copy and redistribute the material in any medium or format for any purpose, even commercially, as long as you attribute the State of Queensland (Department of Transport and Main Roads) 2021. If you remix, transform, or build upon the material, you may not distribute the modified material.

This work is licensed under a [Creative Commons Attribution-No Derivatives 4.0 International License](http://creativecommons.org/licenses/by-nd/4.0/).

CODE S4

Gross Vehicle Mass Rating – Rigid Omnibus

1. Scope

The following is a summary of the ratings which may be approved by officers authorised with modification code S4 – Rigid Omnibus Mass Rating.

Specific requirements for ratings approved under this Code are included later in this Section S4.

Refer also to Section S – Vehicle Rating of *Vehicle Standards Bulletin 6 (VSB-6): National Code of Practice Heavy Vehicle Modifications* for general technical guidelines for ratings performed under this Code.

1.1 Ratings permitted under code S4

This Code is to be used to check that fully laden vehicles of the following type do not exceed the safe mass limits specified by the vehicle manufacturer or the Regulatory Authorities:

- Any rigid omnibus subject to a licence or permits issued in respect to the carriage of both passengers and goods.
- Any rigid omnibus which has been rebodied or has been altered in a manner which affects tare mass, seating layout, standee space, or luggage space.

1.2 Ratings not permitted under code S4

Assessment of the following vehicles are not permitted under this code:

- Articulated Omnibus

2. Compliance with applicable vehicle standards

The vehicle must comply with all applicable Australian Design Rules or Regulations/Acts.

Outlined below in Table S4-1 are areas of the vehicle which may require certification, testing and/or data to show that the vehicle components' ratings will not be exceeded at the vehicle mass rating.

Table S4-1 Summary of items, if modified or altered, may detrimentally affect compliance with applicable ADRs

DETAIL	REQUIREMENT
Brakes	ADR 35, 35A, 35/00 VSB-6 - Section G
Suspension	Manufacturer's rating VSB-6 - Section F
Steering	VSB-6 - Section E

Chassis	Manufacturer's rating VSB-6 - Section H
Engine	ADR 30, 30/00, 36, 36A, 36/00 VSB-6 - Section A
Transmission	VSB-6 - Section B
Tailshaft	VSB-6 - Section C
Axles	Manufacturer's rating VSB-6 - Section D VSB-6 - Section E
Tyres	Manufacturer's rating ADR 24/..

If any of the areas listed above are affected by modifications made to the vehicle in order to achieve the GVM rating they must comply with the prescribed standards and where necessary must be approved by an authorised officer holding the appropriate modification code.

To determine the ADRs that apply to the vehicle in question, the Applicability Tables for individual vehicle categories may be referenced on the Department of Infrastructure and Transport *RVCS* website at the following address and under the section titled *ADR Applicability tables*:

<http://rvcs.dotars.gov.au/>

The ADRs apply according to the vehicle's category and date of manufacture. It is the responsibility of the signatory to refer to the appropriate ADR applicable to the vehicle.

3. Specific requirements

3.1 General

All components must be used within manufacturer's rated capacities. In particular authorised officers must check suspension, axle, drivetrain, chassis, brakes, steering, wheel and tyre capacities.

3.2 Tyres, rims and wheels

The sum of the load carrying capacities recommended for all the tyres and rims with which the vehicle is equipped shall be not less than the GVM.

The load carrying capacity of any tyre or rim must not be exceeded with the vehicle at the revised GVM rating.

For a vehicle manufactured to comply with ADR 24/.. the tyres and rims must be selected and must comply in all respects with the requirements of that ADR at the revised GVM rating.

In the case of vehicles fitted with a 'tyre placard', this placard must indicate the correct tyre specifications for the vehicle at the revised GVM rating.

3.3 Carrying capacity

The vehicle's passenger and luggage capacity and distribution must be assessed to ensure that, in the fully laden condition, the vehicle component's mass ratings are not exceeded.

Checklist S4

CODE S4: Gross Vehicle Mass Rating – Rigid Omnibus

Form No: S4

(N/A= Not Applicable, Y=Yes, N=No)

PROCEDURE

This form is to be completed prior to the Department of Transport and Main Roads inspection of the vehicle. The vehicle details and declaration forms (at the end of Part F and Part G) should be presented with the vehicle at the time of inspection at the Department of Transport and Main Roads Inspection Centre.

APPLICATION CHART

This form is divided into the following parts

- A - PREVIOUSLY APPROVED MODELS OR VEHICLES
- B - UNLADEN (TARE) MASS
- C - MASS OF SEATED PASSENGERS
- D - MASS OF STANDING PASSENGERS
- E - MASS OF LUGGAGE AND TOURING EQUIPMENT

- F - SUMMARY OF MAXIMUM LADEN MASS
- G - REGISTRATION OF DETAILS AND DECLARATIONS

The following chart gives some examples of the more common types of application and indicates those sections which need to be completed. If a vehicle is intended to be used for more than one purpose, each relevant section should be completed. Section F provides for a summary of calculations from each completed section of a route service and non-route service application.

<u>APPLICATION CHART</u>	A	B	C	D	E	F	G
Previously approved (lapsed registration)	✓	✓					✓
Identical to approved vehicle	✓	✓					✓
Route service with standees and no luggage		✓	✓	✓		✓	✓
Non-route service with luggage and no standees		✓	✓		✓	✓	✓
Non-route service with no standees or luggage		✓	✓			✓	✓

Complete all applicable parts

NOTES ON PARTS C, D, E AND F:-

- a) Declarations are required on page 25 by the Authorised Officer who complied the form and by the vehicle owner
- b) In these calculations, measurements shall be stated to the following orders of accuracy:
 - Mass to the nearest kilogram
 - Length to the nearest 5mm
 - Volume to the nearest litre.
- c) "Rear axle line" means the point from which rear overhang is measured.

Part A – Previously Approved Models or Vehicles

PREVIOUS DETERMINATION OF LADEN MASS

I, the owner of the submitted vehicle, declare that the vehicle has not been modified in any way that would affect the vehicle's laden weight since submission of the following "Rigid Omnibus Mass Rating" form.

Serial Number of Previous Form:

Signature of Owner:

Date:

COMPLETE PARTS B AND G ONLY

VEHICLE IDENTICAL TO PREVIOUSLY APPROVED VEHICLE

I, the owner of the submitted vehicle, declare that the vehicle is of identical construction to the vehicle described in the following "Rigid Omnibus Mass Rating" form.

Serial Number of Previous Form:

Signature of Owner:

Date:

COMPLETE PARTS B AND G ONLY

Part B – Unladen Mass

For rating purposes, the unladen mass or tare mass of the vehicle is its actual mass with all permanent equipment fitted, with all oil and water tanks filled and approximately 10 litres of fuel but with no crew or passengers aboard. If the vehicle is to be used for camping tours, the mass of any camping equipment normally provided by the operator must be included in Part E Mass of Luggage.

The bus must be weighed at a registered public weighbridge to determine the actual loads on the front axle and rear axle (or axle groups).

ATTACH WEIGHBRIDGE TICKET HERE

VEHICLE MANUFACTURERS SPECIFICATIONS TO BE ATTACHED

Details to include make, model, year of manufacture, front and rear axle manufacturers and specifications.

WRITE AXLE LOADS IN BOXES BELOW FROM WEIGHBRIDGE TICKET OR AS ESTIMATED

Front Axle Tare Mass (FAx) = kg

Rear Axle Tare Mass (RAx) = kg

Aggregate Weight = kg

For the purposes of determining laden mass of the vehicle, the mass of two thirds of the fuel tank capacity is included.

Capacity of fuel tank (Ff) =l

Volume of fuel when weighed (Fw) =l

Wheelbase of vehicle (Wb) =m

Distance from rear axle line to centre of fuel tank (Df) =m

Density of fuel: Diesel = 0.85kg/l*; Petrol = 0.78kg/l*

*Circle appropriate density.

Additional front axle load due to fuel is given by:

$$FFu = (.66 Ff - Fw) \times \text{DensityFuel} \times Df \div Wb$$

$$= (.66 \times \dots - \dots) \times \dots \times \dots \div \dots$$

FFu = kg

Additional rear axle load due to fuel is given by:

$$Rfu = (.66 Ff - Fw) \times \text{DensityFuel} - FFu$$

$$= (.66 \times \dots - \dots) \times \dots - \dots$$

Rfu = kg

**ADD THE TARE MASS (Page 8) TO THE FUEL MASS
TO OBTAIN TOTAL UNLADEN MASS**

F_{Ax} plus F_{Fu}

R_{Ax} plus R_{Fu}

FRONTkg F _{Un}

UNLADEN
MASS

DRIVEkg R _{Un}

Part C – Mass of Seated Passengers

Draw a plan of the seating arrangements in the space below, including the driver's seat. (Use an additional blank sheet if the bus has two decks and make a calculation for each deck.) Mark in the position of the rear axle line.

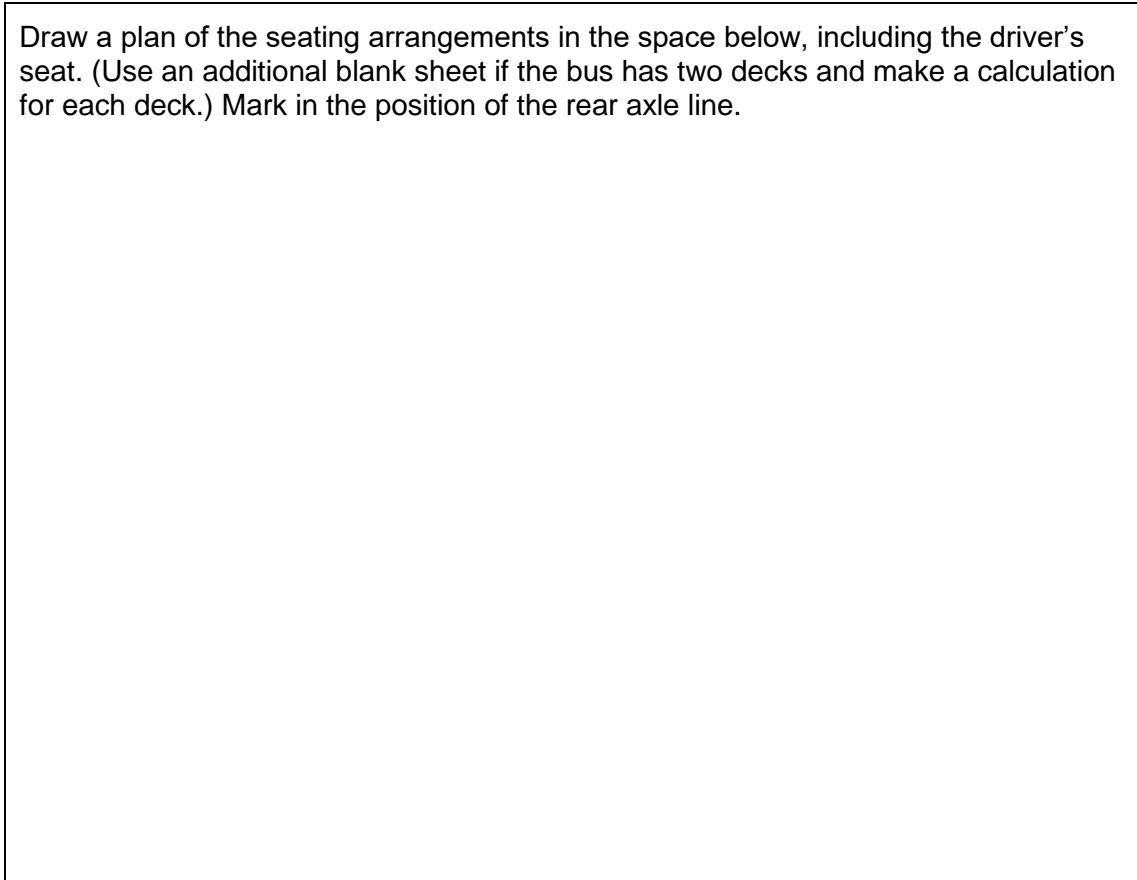

Number each seat, row or group of seats (include the driver's seat as number one). Enter at the top of the table overleaf, the wheelbase of the vehicle, and then the number of seating positions for each seat, row or group.

Enter the longitudinal distance measured from one rear axle line to the seating reference point for each seat (i.e.. On the centre of the seating position and 150mm towards the front of the seat from the intersection of the seat cushions and seat back). **Note:** that only one entry is required for each transverse row of seats if they are the same distance from the rear axle line. If a group of transverse seats are evenly distributed along the bus, only one entry is required, the longitudinal measurement being the average of the distance to the foremost seating reference point and to the rearmost seating reference point of the group. Similarly, longitudinal seats need only one entry, the longitudinal measurement being to the centre of the seat. See following example of seat grouping.

EG.

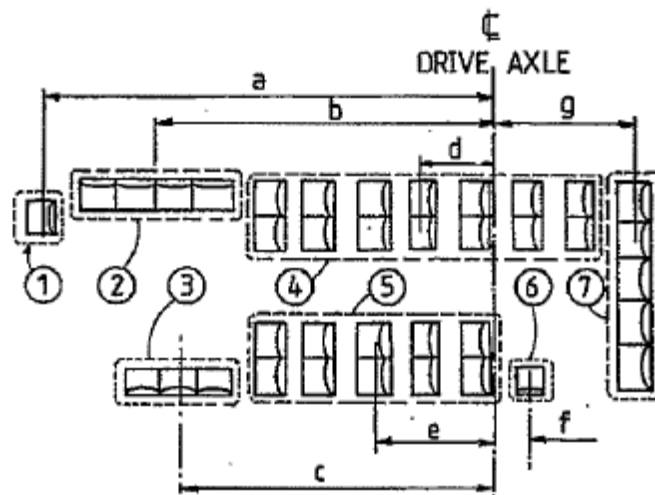

Determine the seated loading factor separately for those seats in front of and those behind the rear axle line, by multiplying the number of seating positions by the longitudinal distance from the rear axle line and adding to get a sub-total.

Subtract the sub-total for the rear seats from that for the front seats.

If any seating reference point is above the rear axle line, that seat should be considered in front of the rear axle line, but the distance and load factor will be zero.

AXLE LOADS DUE TO SEATED PASSENGERS			
Vehicle wheelbase:metres			
(i) Seating Position	(ii) Number of Occupants	(iii) Distance from Rear Axle (m)	(iv) Load Factor (ii) x (iii)
Seating Reference Point in front of rear axle line			
1. Driver	1		
Sub-Total			A=
Seating Reference Point behind rear axle line			
Sub-Total			B=
Total Occupants		Seated Loading Factor, (SLF) = A – B =	

The front axle load due to seated passengers is based on an average passenger mass of 65kg and is calculated below:

$$\begin{aligned} \text{Front Axle Load (Seating)} &= \frac{\text{Seated Loading Factor} \times 65\text{kg}}{\text{Wheelbase}} \\ &= \frac{\dots \times 65}{\dots} \end{aligned}$$

FSe =kg

The rear axle load due to seated passengers is the total person mass minus the front axle load.

$$\begin{aligned} \text{Rear Axle Load (Seating)} &= (\text{Total Occupants} \times 65\text{kg}) - \text{FSe} \\ &= (\dots \times 65 - \dots) \end{aligned}$$

RSe =kg

WRITE FRONT AND REAR AXLE LOADS DUE TO SEATED PASSENGERS HERE

<p>FRONT</p> <p>.....kg</p> <p>FSe</p>
--

SEATED

MASS

<p>REAR</p> <p>.....kg</p> <p>RSe</p>

Part D – Mass of Standing Passengers

This section is to be completed only if application is being made for assignment of a standing capacity.

Draw a plan of the standing spaces in the rear section in the spaces below, excluding 200mm allowance in front of each seat for foot space for seated passengers. Mark each space that is to be used by standing passengers in rectangular portions. Mark in the position of the rear axle line.

Measure the length and width and calculate the area of each rectangular standing space. The table on the next page can be used for calculations. Measure the distance from the rear axle line to the centre of each standing space.

For example:

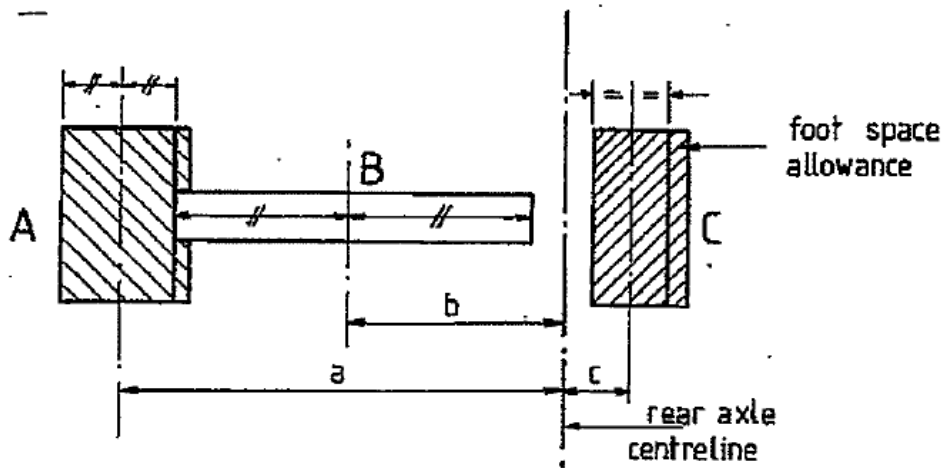

Calculate the maximum standing capacity by summing the total standing area and multiplying by 6.25 persons/m². Take the nearest whole number less than this value for maximum standing capacity. The nominated capacity must not be more than this.

Calculate the effective passenger density by dividing nominated capacity by total standing area.

(i) Standing Space	(ii) Length, l (m)	(iii) Width, w (m)	(iv) Area (m ²) (ii)x(iii)	(v) (iv)xED	(vi) Distance from Rear Axle (negative if behind rear axle)	(vii) Standing Loading Factor (v)x(vi)
Total Area				m ³		
						(sum column vii)
Total Standing Area (TSA) = m ²						
Maximum Standing Capacity = TSA x6.25 = persons						
Nominated Standing Capacity (NSC) = persons						
Effective Density (ED) = NSC/TSA = /						
ED = persons/ m ²						
Standing Loading Factor =						

The axle loads due to standing passengers are based on an average passenger mass of 65kg and are calculated below:

$$\text{Front Axle Load (standing) FSt} = \frac{\text{Standing Loading Factor} \times 65\text{kg}}{\text{Wheelbase}}$$

$$= \frac{\dots \times 65}{\dots}$$

$$\text{FSt} = \dots \text{kg}$$

$$\text{Rear Axle Load (standing) RSt} = (\text{Nominated Standing capacity} \times 65) - \text{FSt}$$

$$= (\dots \times 65 - \dots)$$

$$\text{RSt} = \dots \text{kg}$$

WRITE FRONT AND REAR AXLE LOADS DUE TO STANDING PASSENGERS HERE

<p>FRONT</p> <p>.....kg</p> <p>FSt</p>
--

STANDING
MASS

<p>REAR</p> <p>.....kg</p> <p>RSt</p>

Part E – Mass of Luggage and Touring Equipment

This section is to be completed only if the vehicle is equipped with specific areas for the loading of passengers' luggage and in any special touring equipment.

Draw a plan of spaces on the bus that are set aside for the carriage of luggage (disregard compartments that are intended only for lightweight personal effects such as hat racks). Mark in the position of the rear axle line.

Measure the average length, width and height of each luggage compartment. In the cases where the compartment is a non-rectangular shape, it may be easier to divide the compartment into smaller box-like sections. The table on the next page can be used for calculations.

Measure the distance from the rear axle line to the centre of volume of each luggage compartment or section. Where the section has a consistent height, the centre will be the centre of the floor area.

For example:

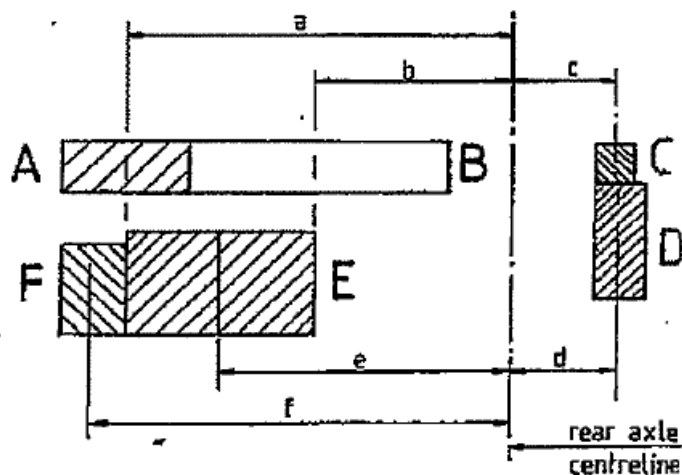

Calculate the effective luggage density by summing the total passenger luggage mass (ie. number of occupants including the driver times 15kg/person) and the mass of any touring equipment provided by the operator.

Calculate the mass of luggage in each luggage space by multiplying the volume of each space by the effective luggage density, ED. (see NOTE ON EFFECTIVE DENSITY, ED.) This is then multiplied by the distance from the rear axle line to the centre of each luggage space. These values are then added together to determine the Principal Luggage Factor. Note if the centre of any luggage space is behind the rear axle line, the loading factor is subtracted rather than added.

(i) Luggage Space	(ii) Length (m)	(iii) Width (m)	(iv) Height (m)	(v) Luggage Volume (m ³) (ii)x(iii)x(iv)	(vi) (v)xED Or (v)x100 SEE NOTE	(vi) Distance from Rear Axle (negative if behind rear axle)	(vii) Luggage Loading Factor (vi)x(vii)
Total Luggage Volume (TLV)					m ³	PLF =	
							(sum column viii)
<p>Total Luggage Mass = No. of occupants including driver x 15kg/person plus mass of equipment = (..... x 15) +</p> <p>TLM = kg</p> <p>Effective Density = Total Luggage Mass (TLM) / Total Luggage Volume = /</p> <div style="border: 1px solid black; padding: 5px; display: inline-block;">ED = kg/m³</div> <p style="text-align: right;">SEE NOTE</p> <p>Principal Luggage Factor (PLF) = kg/m²</p>							

NOTE ON EFFECTIVE DENSITY, ED

An allowance has been made in the determination of Effective Density to provide for inevitable inefficiencies in packing passenger luggage into the luggage space. A maximum value of 100kg/m³ has been established allowing for packing irregularities, structural interference in the luggage space and inaccessibility to the full luggage space.

If the calculated Effective Density is less than or equal to 100kg/m³, the calculated figure must be used in column 6. If the calculated Effective Density is greater than 100kg/m³, two options are available:

- (i) All luggage will be considered as stored in the luggage space and the calculated figure for Effective Density must be used; or
- (ii) Some of the luggage will be considered as distributed amongst the seated passengers, in which case the figure of 100kg/m³ must be used for Effective Density in column 6. Distribution of the Residual Luggage is calculated over the page.

Note: Complete this section only if the calculated Effective Density is greater than 100kg/m³, some of the luggage is to be considered as distributed amongst the seated passengers, and you have used 100kg/m³ in the previous table instead of the calculated Effective Density.

$$\begin{aligned} \text{Residual Luggage Mass} &= \text{Total Luggage Mass} - (\text{Total Luggage Volume} \times 100\text{kg/m}^3) \\ &= \text{TLM} - (\text{TLV} \times 100) \\ &= \dots\dots\dots - (\dots\dots\dots \times 100) \end{aligned}$$

$$\text{RLM} = \dots\dots\dots\text{kg}$$

$$\text{Residual Luggage Factor} = \text{Residual Luggage Mass} / \text{number of occupants including driver}$$

$$= \dots\dots\dots / \dots\dots\dots$$

$$\text{RLF} = \dots\dots\dots$$

The axle loads due to passenger luggage and equipment are calculated below:

Front Axle Load (Luggage)

= Front Axle Residual Luggage + Front Axle Principal Luggage

= (Seated Loading Factor (page 13) x Residual Luggage Factor)

+ Principal Luggage Factor / Wheelbase

= $\frac{(SLF \times RLF) + PLF}{Wb}$

Wb

= $(\dots \times \dots) + \dots$

.....

FLu =kg

Rear Axle Load (Luggage)

= Total Luggage Mass – Front Axle Load (Luggage)

= TLM – FLu

= -

RLu =kg

WRITE FRONT AND REAR AXLE LOADS DUE TO LUGGAGE HERE

FRONT
.....kg
FLu

LUGGAGE

MASS

REAR
.....kg
RLu

Part F – Maximum Laden Mass

If this vehicle is to be used as a Motor Omnibus (ROUTE SERVICE) complete the following where applicable: (in most cases luggage mass will not be applicable)			
	FRONT AXLE GROUP	REAR AXLE GROUP	TOTAL
UNLADEN MASS (Page 10)	FUn	RUn
SEATED MASS (Page 14)	FSe	RSe
STANDING MASS (Page 17)	FSt.....	RSt
LUGGAGE MASS (Page 21)	FLu	RLu
(A) GROSS LADEN MASS (kg)
(B) CHASSIS MANUFACTURER'S LOAD LIMITS (GVM)
TYRE DESIGNATIONx.....x.....	
PLY TYPE/RATING	Radial/.....Bias	Radial/...Bias	
NO. OF AXLES/NO. OF TYRES/...../.....	
(C) RECOMMENDED TYRE LOAD LIMITS	
(D) DEPARTMENT OF TRANSPORT AND MAIN ROADS LIMITS	
Is the GROSS LADEN MASS (A) less than or equal to the above limits (B, C, D)?			
If YES, this vehicle is suitable for registration for ROUTE SERVICE:			
Seated capacity Standing capacity Luggage YES/NO			

If this vehicle is to be used as a Service Omnibus / Special Purpose Omnibus complete the following where applicable: (in most cases standing mass will not be applicable)

	FRONT AXLE GROUP	REAR AXLE GROUP	TOTAL
UNLADEN MASS (Page 10)	FUn	RUn
SEATED MASS (Page 14)	FSe	FSe
STANDING MASS (Page 17)	FSt.....	RSt
LUGGAGE MASS (Page 21)	FLu	RLu
(E) GROSS LADEN MASS (kg)
(F) CHASSIS MANUFACTURER'S LOAD LIMITS (GVM)
TYRE DESIGNATIONx.....X.....	
PLY TYPE/RATING	Radial/.....Bias	Radial/...Bias	
NO. OF AXLES/NO. OF TYRES/...../.....	
(G) RECOMMENDED TYRE LOAD LIMITS	
(H) DEPARTMENT OF TRANSPORT AND MAIN ROADS LIMITS	
Is the GROSS LADEN MASS (E) less than or equal to the above limits (F, G, H)?			
If YES, this vehicle is suitable for registration for NON-ROUTE SERVICE:			
Seated capacity Standing capacity Luggage YES/NO			

Note: If the Gross Laden Mass EXCEEDS any of these limits, the bus or coach will not be approved and the passenger or luggage compartment must be review.

Note: Declarations by the person who completed the calculations and the owner are required on page 25.

This page has been left blank for any additional calculations

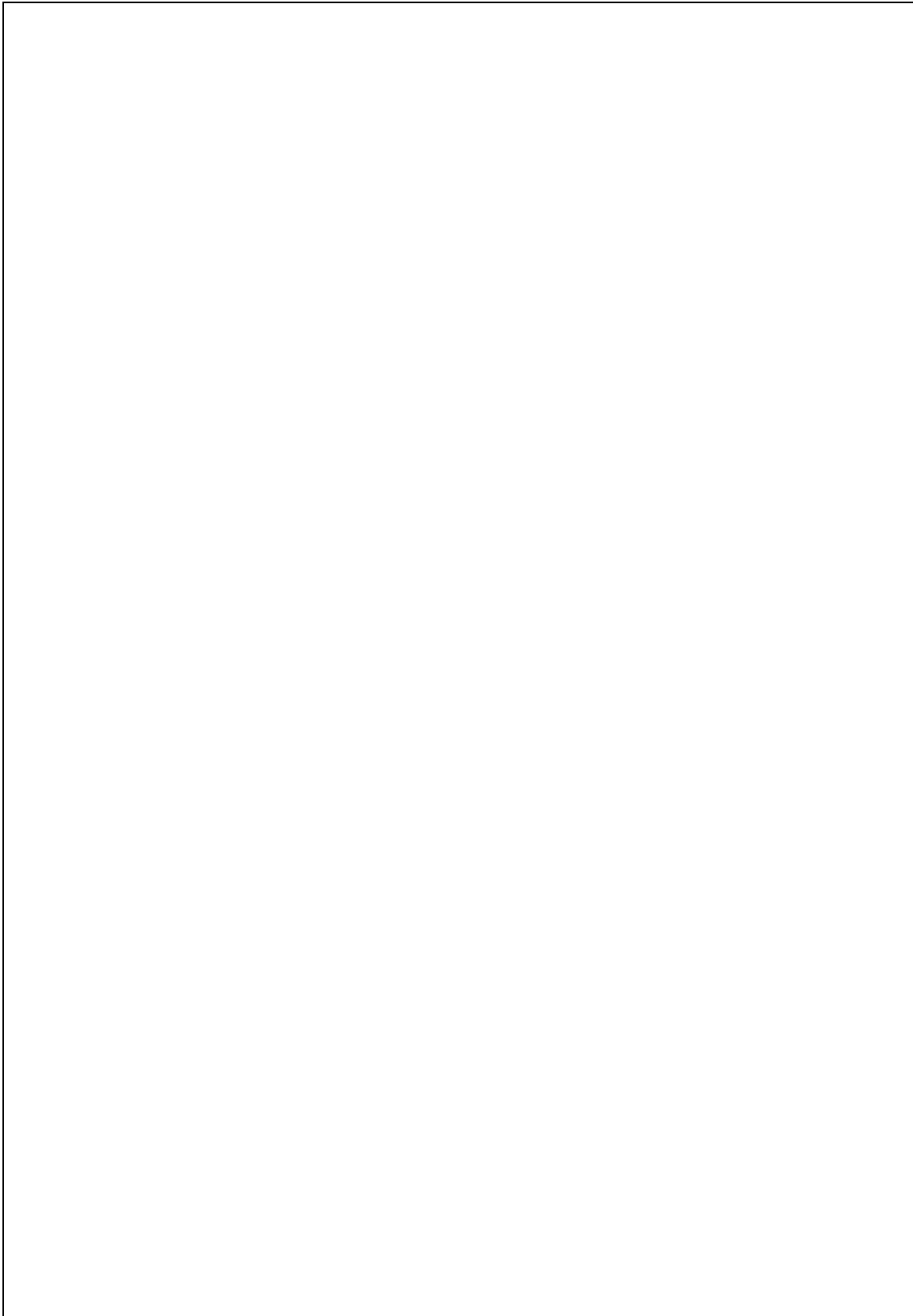

Part F (continued) – Declarations

DECLARATION BY COMPLIER*			
Authorised Officer			
MA Number			
I am the authorised officer who completed the calculations of laden mass and declare that the information in this form is true and correct.			
Signature		Date	
Company/Business		Telephone	

DECLARATION BY VEHICLE OWNER*			
Vehicle Owner			
Owner's Address			
Name of Authorised Officer			
As the owner of the vehicle described in this form, I declare that the calculations have been completed by the authorised officer mentioned above.			
Signature		Date	
Company/Business		Telephone	

* Declarations by the Authorised Officer and owner must be completed before presentation of the vehicle for inspection at the Department of Transport and Main Roads Inspection Centre.

Part G – Vehicle Details and Declarations

Vehicle Owner's Details																	
Name																	
Company / Business																	
Address																	
Vehicle Information																	
Make					Model					Date of Manufacture							
VIN																	
Chassis No (if applicable)							Engine Number										
Engine Capacity			Number of Cylinders				Fuel Type										
Body Type							Body Colour										
Overall Body Length			Front Overhang				Rear Overhang										
Axle Specifications																	
Front Axle Make							Capacity										
Drive Axle Make							Capacity										
Rear Axle Make							Capacity										
Tag/Tandem Axle Make (if applicable)							Capacity										
Only for previously registered vehicles																	
Registration							State/Territory										
Name and Address of Most Recent Owner																	

The vehicle described in this form has been assessed for axle load compliance with the following passenger capacities

Motor Omnibus (Route Service)

Seated		Standing		Luggage	Yes / No
---------------	--	-----------------	--	----------------	-----------------

Service/Special Purpose Omnibus (Non-Route Service)

Seated		Standing		Luggage	Yes / No
---------------	--	-----------------	--	----------------	-----------------

Authorised officer who examined and approved vehicle

Name

Company / Business

MA Number

Signature **Date**